

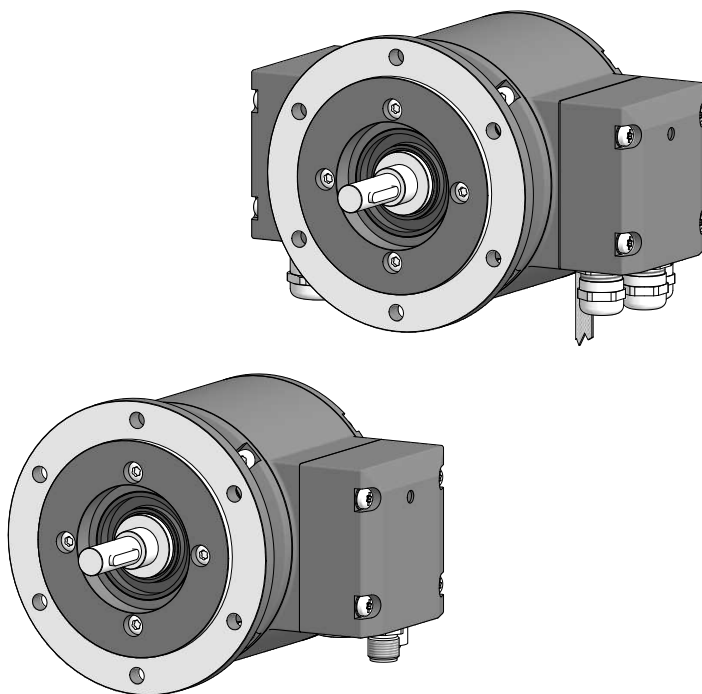

Installation and operating instructions



PMG 10 - CANopen® **Absolute Encoder** **with magnetic sensing**

TABLE OF CONTENTS

1. IMPORTANT NOTES	1
1.1 Symbol guide	1
1.2 Intended use	1
1.3 Exclusion from liability	1
1.4 Maintenance and lifetime	2
1.5 Approvals and warranty	2
1.6 Storage temperature and disposal	2
2. SAFETY AND ATTENTION INSTRUCTIONS	3
2.1 Safety instructions	3
2.2 Attention instructions for mounting and operation	4
3. PREPARATION	5
3.1 Scope of delivery	5
3.2 Required accessory for mounting (not included in scope of delivery)	6
3.3 Required tools (not included in scope of delivery)	6
4. MOUNTING	7
4.1 Mounting the spring disk coupling to the encoder	7
4.2 Mounting to drive shaft	7
4.3 Mounting the spring disk coupling to drive shaft	8
4.4 Maximum permissible mounting tolerance when the Baumer Hübner K 35 spring disk coupling is used	9
4.5 Note when using a jaw-type coupling (for example „ROTEX®“)	10
5. ELECTRICAL CONNECTION	11
5.1 CANopen®	11
5.1.1 Features	11
5.1.2 Cable connection for version with cable glands	12
5.1.3 Bus connecting box CANopen® [A] - Version with connectors	13
5.1.3.1 Connector M12 [C] (male, 5-pin, A-coded)	13
5.1.3.2 Connector M12 [D] (female, 5-pin, A-coded)	13
5.1.4 View in bus connecting box CANopen® [A]	14
5.1.5 Setting for the terminating resistors	14
5.1.6 Setting for the user address	14
5.1.7 Setting for the transmission rate	15

5.2	Speed switch and additional output incremental	15
5.2.1	Terminal significance	15
5.2.2	Output signals incremental (additional output)	16
5.2.3	LED function displays	16
5.2.4	Speed switch - Switching characteristics	17
5.2.5	Cable connection	18
5.2.6	Assignment connecting terminal	19
5.2.6.1	Connecting terminal box [B] Speed switch without additional output	19
5.2.6.2	Connecting terminal box [B] Speed switch with additional output	19
6.	DIMENSION	20
7.	DISMOUNTING	21
8.	TECHNICAL DATA	22
8.1	Technical data - electrical ratings	22
8.2	Technical data - electrical ratings (speed switches)	22
8.3	Technical data - mechanical design	23

1. IMPORTANT NOTES

1.1 Symbol guide



Warning

Disregarding could result in serious injury, death or damage to property



Attention

Disregarding could result in damage to property or damage/malfunction of the encoder



Information

Additional information and recommendations

1.2 Intended use

The encoder is a precision measurement device for the acquisition of speed/position information for the control of drive units and the provision of electronic output signals for downstream devices.

The encoder must not be used for any other purpose. The function of the encoder is described in this mounting instruction. The customer must check the suitability for the purpose intended.

Mounting and selection must be executed by authorized and qualified personnel. Mounting, electrical commissioning or any other work with the encoder or system is to be performed by appropriately qualified staff only.

Do not put encoder into service if there is any visible evidence of damage.

Do not operate encoder beyond the limit values stated in this mounting instruction.

Any risk of personal injury, damage of the system or company equipment due to failure or malfunction of the encoder must be eliminated by corresponding safety measures.



Warning

Disregarding intended use could result in serious injury or damage to property.

1.3 Exclusion from liability

The manufacturer is not liable for any damage to persons or property resulting from unintended use of the encoder.

1.4 Maintenance and lifetime

The encoder may be only opened as described in this instruction. Repair or maintenance work that requires opening the encoder completely must be carried out by the manufacturer.

Alterations of the device are not permitted.

The expected operating life of the device depends on the ball bearings, which are equipped with a permanent lubrication.

In the event of queries or subsequent deliveries, the data on the device type label must be quoted, especially the type designation and the serial number.

1.5 Approvals and warranty

EU Declaration of Conformity meeting to the European Directives.

We grant a 2-year warranty in accordance with the regulations of the Central Association of the German Electrical Industry (ZVEI).



Warranty seal

Damaging the warranty seal on the encoder invalidates warranty.

1.6 Storage temperature and disposal

The storage temperature range of the encoder is between $-15...+70$ °C (caused by packing).

Encoder components are to be disposed of according to the regulations prevailing in the respective country.

2. SAFETY AND ATTENTION INSTRUCTIONS

2.1 Safety instructions



Explosion risk

Spark formation can cause a fire or an explosion.

- » Do not use the encoder in areas with explosive and/or highly inflammable materials. They may explode and/or catch fire by possible spark formation.



Risk of serious injuries due to rotating shafts

Hair and clothes may become tangled in rotating shafts. Touching the rotating parts can cause extremely serious injuries.

- » Before all work switch off all operating voltages and ensure machinery is stationary.
- » Prevent reconnection operating voltages by third parties.



Risk of serious injuries due to consequential damages

Plants can be deregulated due to malfunction or faulty signals of the encoder.

- » Damage caused by faulty operation or by a malfunction of the encoder must be eliminated by corresponding safety measures.







Risk of burns due to formation of heat

The encoder heats up at higher speed so there is a serious risk of burning shortly after the machine has been turned off.

- » Examine carefully whether the encoder overheats. Wear suitable gloves if necessary.

2.2 Attention instructions for mounting and operation

-  Risk of destruction due to electrostatic charge
Electronic parts contained in the encoder are sensitive to high voltages.
 - » Do not touch plug contacts or electronic components.
 - » Protect output terminals against external voltages.
 - » Do not exceed max. operating voltage.
-  Risk of destruction due to mechanical overload
Rigid mounting may give rise to constraining forces.
 - » Never restrict the freedom of movement of the encoder. The installation instructions must be followed.
 - » It is essential that the specified clearances and/or angles are observed.
-  Risk of destruction due to mechanical shock
Violent shocks, e. g. due to hammer impacts, can lead to the destruction of the sensing system.
 - » Never use force. Assembly is simple when correct procedure is followed.
 - » Use suitable puller for disassembly.
-  Risk of destruction due to contamination
Dirt penetrating inside the encoder can cause short circuits and damage the optical sensing system.
 - » Absolute cleanliness must be maintained when carrying out any work on the open terminal box.
 - » When dismantling, never allow lubricants to penetrate the encoder.
-  Risk of destruction due to adhesive fluids
Adhesive fluids can damage the optical sensing system and the bearings. Dismounting an encoder, secured to a shaft by adhesive may lead to the destruction of the unit.
 - » Do not use adhesive fluids for fixing.

3. PREPARATION

3.1 Scope of delivery

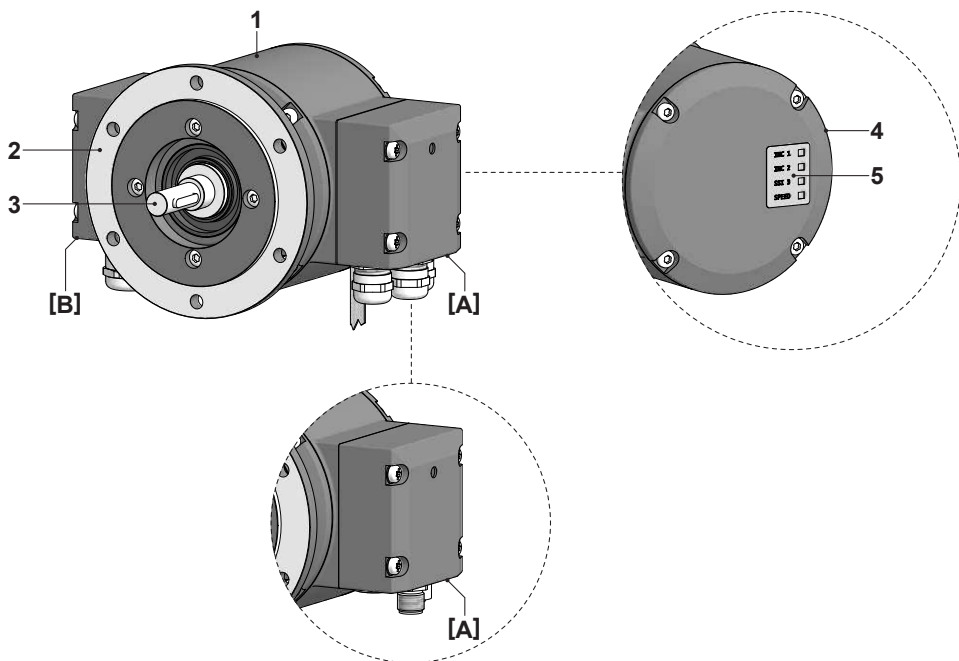

- 1 Housing
- 2 EURO flange B10
- 3 Solid shaft with key
- 4 Bearing shield
- 5 LED function indicators

Radial terminal boxes* (see *section 5*):

- [A] Bus connecting box CANopen®
- [B] Speed switch + additional output

* Depending on version

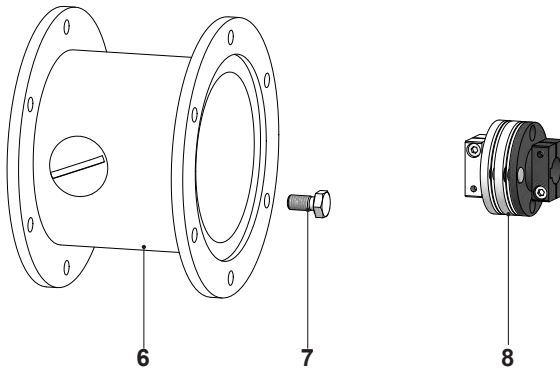

3.2 Required accessory for mounting (not included in scope of delivery)

i Connecting cables and connectors are required for the electrical connection. Details see *section 5, page 11*.



- 6** Installation fitting, customized
- 7** Fixing screws for installation fitting ISO 4017, M6x16 mm
- 8** Spring disk coupling K 35, available as accessory, see *section 4.4, page 9*.

3.3 Required tools (not included in scope of delivery)

-  2.5 mm
-  10 and 22 mm
-  TX 10, TX 20

4. MOUNTING

4.1 Mounting the spring disk coupling to the encoder

We recommend using the Baumer Hübner spring disk coupling K 35, see *section 4.4, page 9*, available as accessory. When other couplings are used pay attention to manufacturer's notes.

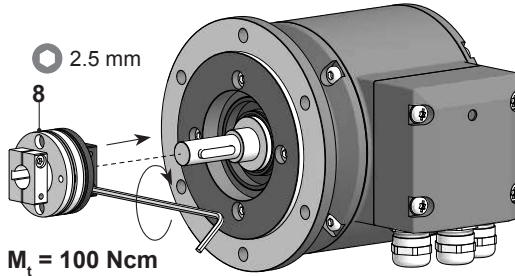

4.2 Mounting to drive shaft

 Lifetime restrictions and angle error by radial deviations
 High runout of the drive shaft can cause encoder angle error.
 High runout of the drive shaft can cause vibrations, which can shorten the lifetime of the encoder.

- » Lubricate drive shaft!
- » Minimize drive shaft runout ($\leq 0.2 \text{ mm}$; $\leq 0.03 \text{ mm}$ recommended).

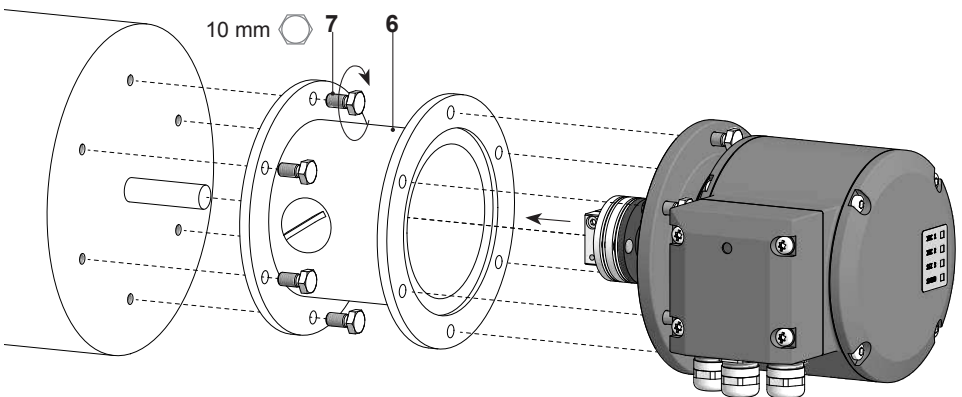

 The encoder must be mounted with cable connection facing downward and not exposed to water.

4.3 Mounting the spring disk coupling to drive shaft

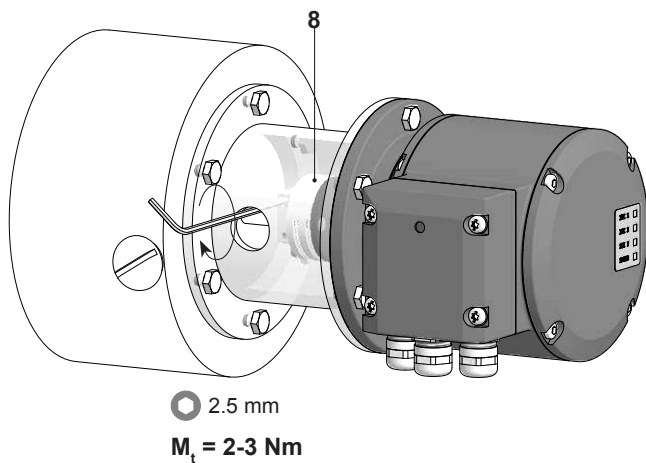

4.4 Maximum permissible mounting tolerance when the Baumer Hübner K 35 spring disk coupling is used

Encoders should be driven through the Baumer Hübner K 35 spring disk coupling (accessory), that can be pushed onto the shaft without axial loading.

- ☞ The encoder must be mounted on the drive with the least possible angular error and parallel misalignment.
- ☞ Risk of damaging the ball bearings
Coupling components must not be driven onto the shaft with improper force (e. g. hammer impacts), because of the risk of damaging the ball bearings.

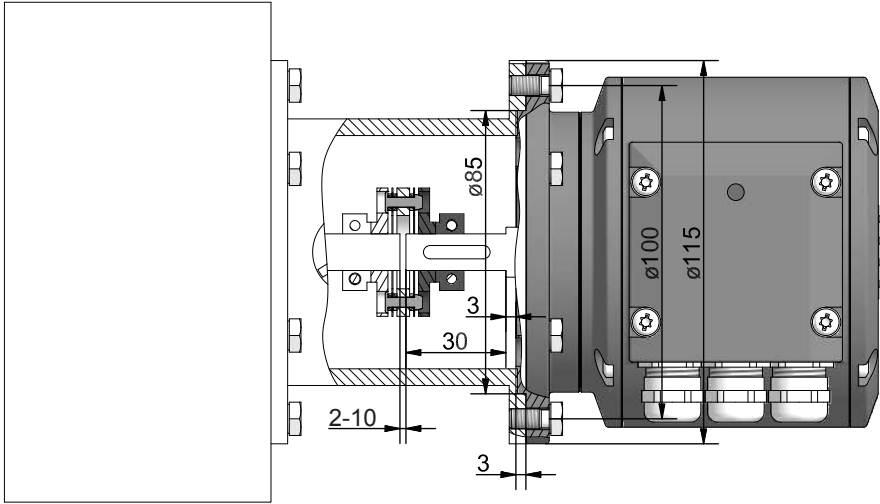

Admissible parallel misalignment

Admissible angular error

Admissible axial movement

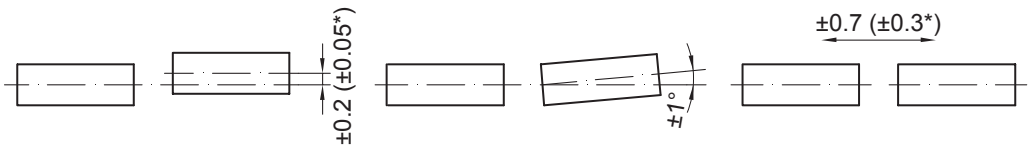

* For insulated hub version

All dimensions in millimeters, unless otherwise stated.

4.5 Note when using a jaw-type coupling (for example „ROTEX®“)

✎ Incorrect mounting of the jaw-type coupling can damage the encoder.
Avoid blocking of both coupling halves (claws pressed together). The encoder shaft must not be subjected to direct axial shock.

- » Use a depth gauge to find and observe the correct distances (**L**, **L1**), see below.

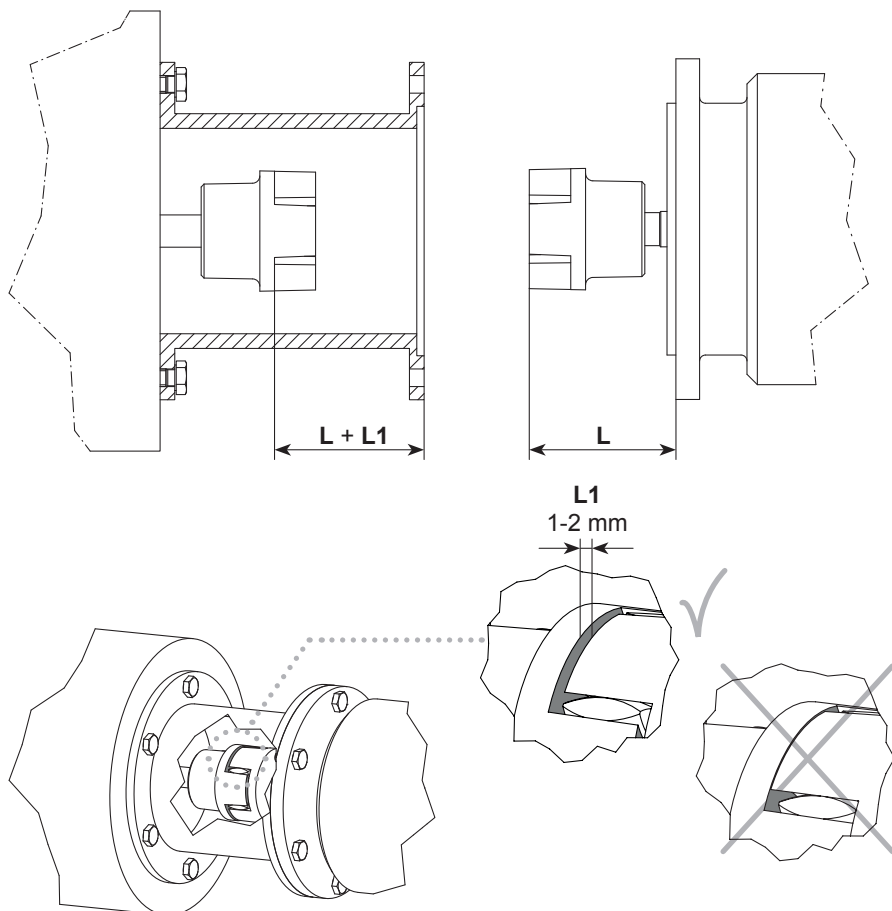

5. ELECTRICAL CONNECTION

5.1 CANopen®

i Please find a detailed instruction for the CANopen® interface and the device description file in the manual on the CD provided with the device.

5.1.1 Features

Bus protocol	CANopen®
CANopen® features	Device Class 2 CAN 2.0B
Device profile	CANopen® CiA DSP 406, V 3.0
Operation modes	Polling mode (asynch, via SDO) Cyclic mode (asynch-cyclic) Synch mode (synch-cyclic) Acyclic mode (synch-acyclic)
Diagnostic	The encoder supports the following error messages: - Position error
Default settings	User address 00

5.1.2 Cable connection for version with cable glands

☞ To ensure the specified protection of the device the correct cable diameter must be used.

Connecting cables are not in scope of delivery.

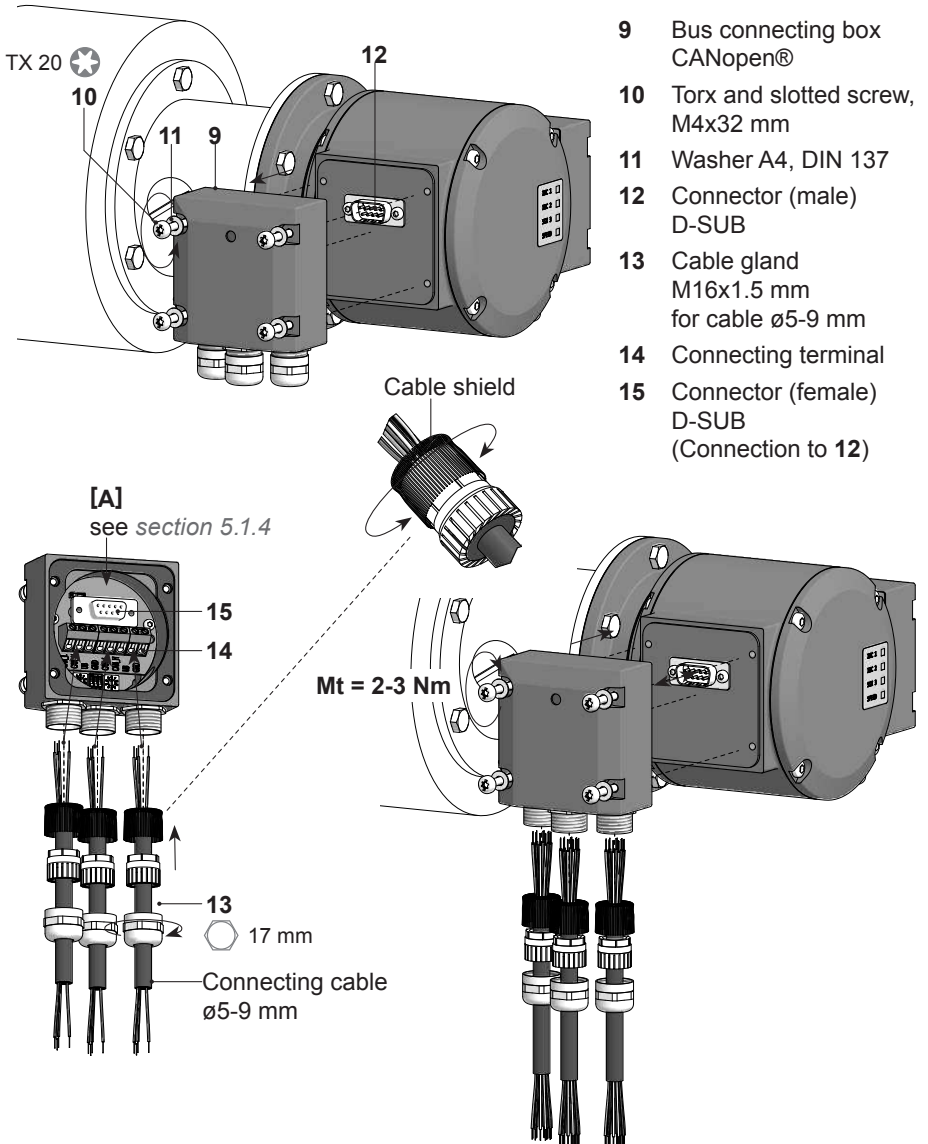

5.1.3 Bus connecting box CANopen® [A] - Version with connectors

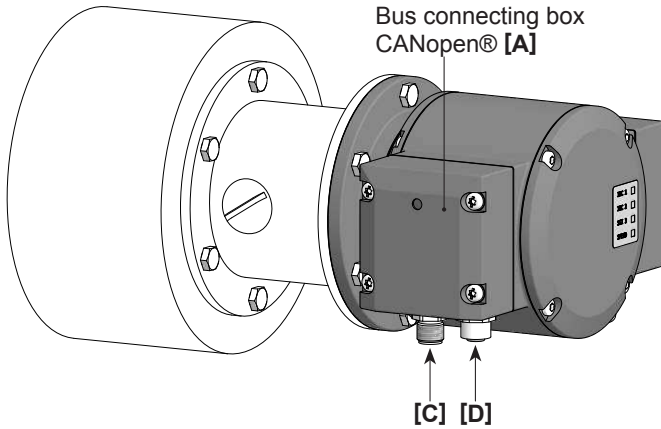

5.1.3.1 Connector M12 [C] (male, 5-pin, A-coded)

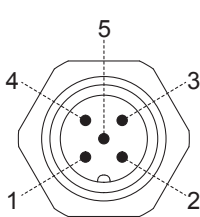
	MALE	CONNECTION	DESCRIPTION
	1	GND	Ground for UB
	2	UB	Voltage supply 10...30 VDC
	3	GND	Ground for UB
	4	CAN_H	CAN bus signal (dominant HIGH)
	5	CAN_L	CAN bus signal (dominant LOW)

5.1.3.2 Connector M12 [D] (female, 5-pin, A-coded)

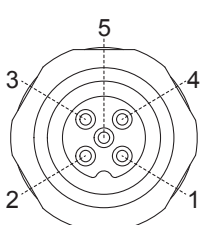
	FEMALE	CONNECTION	DESCRIPTION
	1	GND	Ground for UB
	2	UB	Voltage supply 10...30 VDC
	3	GND	Ground for UB
	4	CAN_H	CAN bus signal (dominant HIGH)
	5	CAN_L	CAN bus signal (dominant LOW)

5.1.4 View in bus connecting box CANopen® [A]

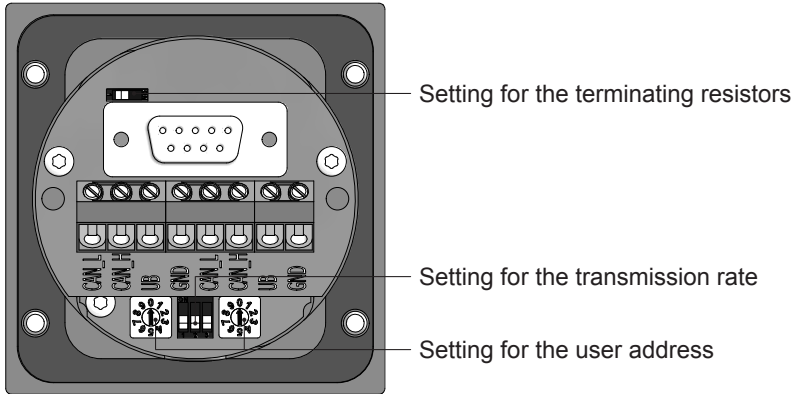

Terminal assignment

GND Ground for UB

UB Voltage supply 10...30 VDC

CAN_H CAN bus signal (dominant HIGH)

CAN_L CAN bus signal (dominant LOW)

i Terminals of the same significance are internally connected and identical in their functions. Max. load on the internal terminal connections UB-UB and GND-GND is 1 A each.

5.1.5 Setting for the terminating resistors

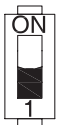

ON = Last user

OFF = User x

5.1.6 Setting for the user address

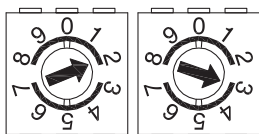

Address can be set by rotary switches. Example: User address 23

5.1.7 Setting for the transmission rate

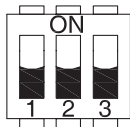

TRANSMISSION RATE	DIP SWITCH POSITION		
	1	2	3
10 kBaud	OFF	OFF	OFF
20 kBaud	OFF	OFF	ON
50 kBaud (default)	OFF	ON	OFF
125 kBaud	OFF	ON	ON
250 kBaud	ON	OFF	OFF
500 kBaud	ON	OFF	ON
800 kBaud	ON	ON	OFF
1000 kBaud	ON	ON	ON

5.2 Speed switch and additional output incremental

5.2.1 Terminal significance

+UB	Voltage supply
⊥	Ground
A+	Channel A+
A-	Channel A- (Channel A+ inverted)
B+	Channel B+
B-	Channel B- (Channel B+ inverted)
R+	Zero pulse (reference signal)
R-	Zero pulse inverted
nE+	System OK+ / error output
nE-	System OK- / error output inverted
SP+*	DSL_OUT1 / speed switch (Open-Collector** or Solid State Relay**)
SP-*	DSL_OUT2 / speed switch (0 V** or Solid State Relay**)
SA*	RS485+ / programming interface
SB*	RS485- / programming interface
dnu	Do not use

* Only at version with speed switch

** Depending on version

5.2.2 Output signals incremental (additional output)

At positive rotating direction

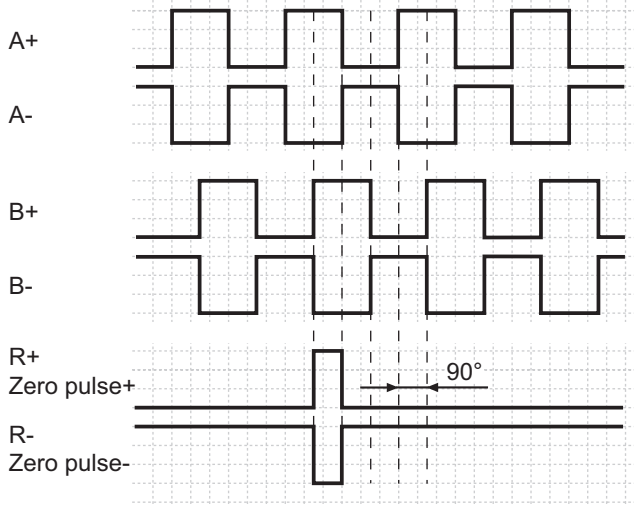

5.2.3 LED function displays

LED	Red	Green
INC1	Without function	Without function
INC2 (additional output incremental)	Undervoltage Overload Over-temperature	OK
Status	Internal error	OK
Speed	Speed higher switching speed (overspeed)	Speed lower switching speed

5.2.4 Speed switch - Switching characteristics

Event	State of the speed switch output
During initialisation	High resistance (overspeed)
After initialisation and speed $\leq -ns$ (off)	High resistance (overspeed)
$-ns$ (off) < speed $\leq -ns$ (on)	State unchanged Low resistance (no overspeed) after initialisation if the encoder is rotating between the switching range during initialisation.
$-ns$ (on) < speed < $+ns$ (on)	Low resistance (no overspeed)
$+ns$ (on) \leq speed < $+ns$ (off)	State unchanged Low resistance (no overspeed) after initialisation if the encoder is rotating between the switching range during initialisation.
$+ns$ (off) \leq speed	High resistance (overspeed)

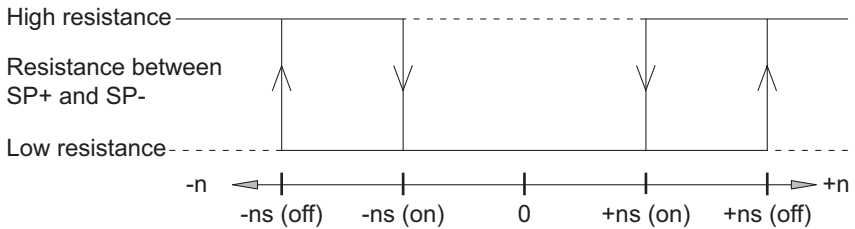

n = Speed

$+ns$ (on) = Activation speed at shaft rotation in positive rotating direction*

$+ns$ (off) = Deactivation speed at shaft rotation in positive rotating direction*

$-ns$ (on) = Activation speed at shaft rotation in negative rotating direction*

$-ns$ (off) = Deactivation at shaft rotation in negative rotating direction*

* See section 6, page 20

5.2.5 Cable connection

- ☞ To ensure the specified protection of the device the correct cable diameter must be used.

Connecting cables are not in scope of delivery.

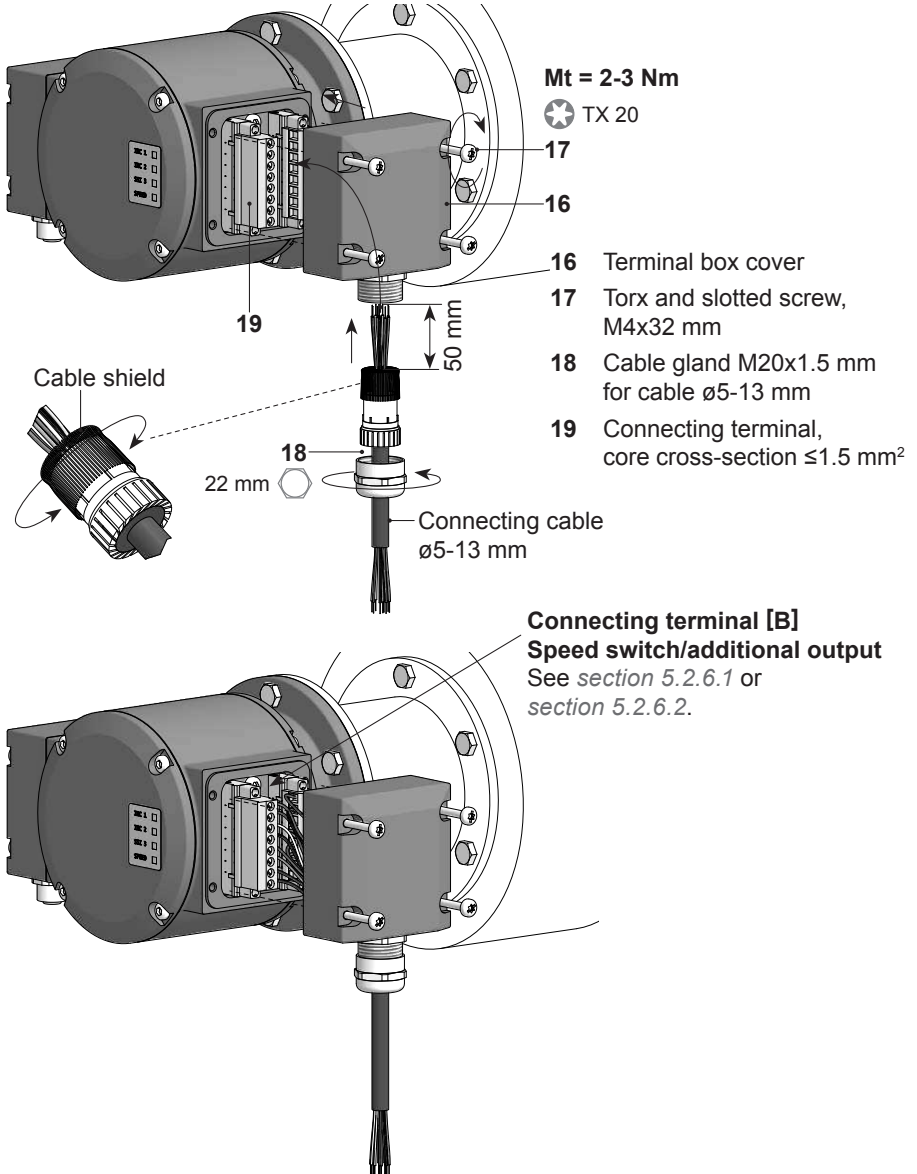

5.2.6 Assignment connecting terminal

 Do not connect voltage supply to outputs! Danger of damage!
Please, beware of possible voltage drop in long cable leads (inputs and outputs)!

5.2.6.1 Connecting terminal box [B] Speed switch without additional output

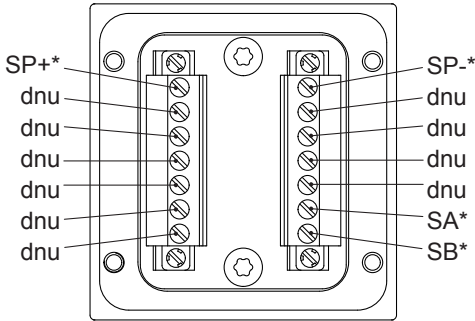

5.2.6.2 Connecting terminal box [B] Speed switch with additional output

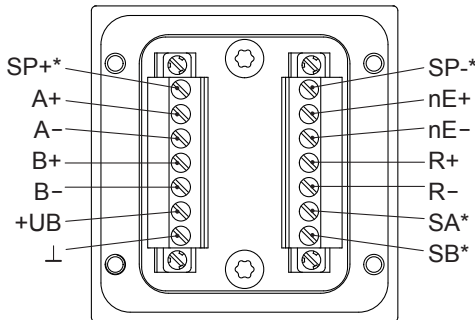

* Only at version with speed switch

6. DIMENSION

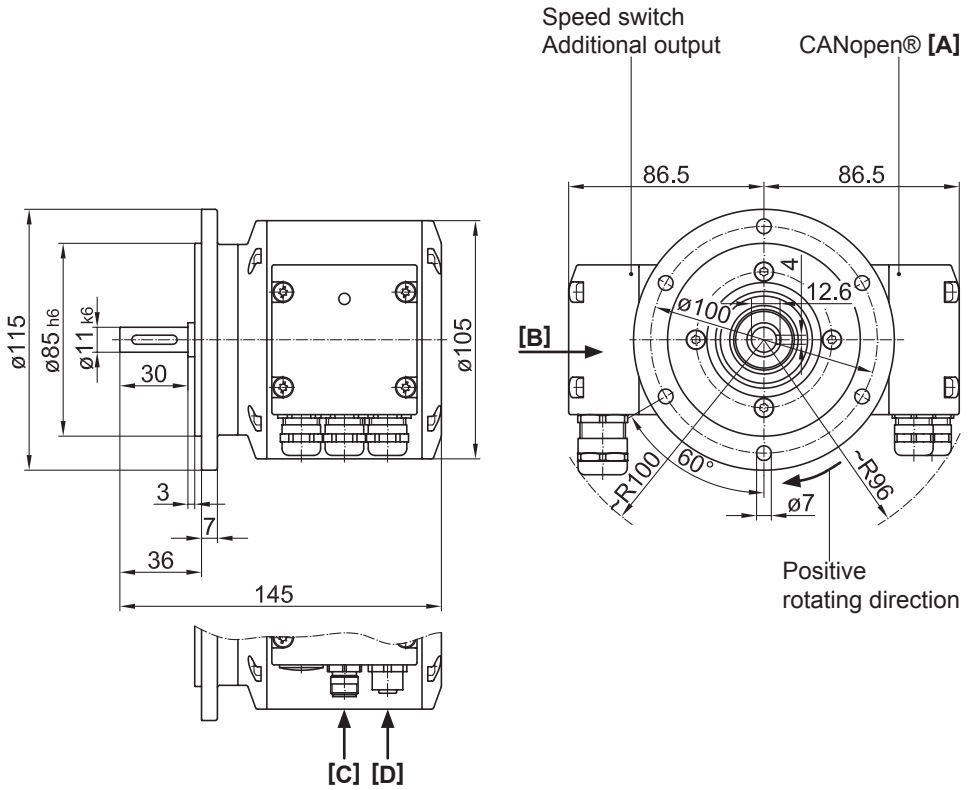

All dimensions in millimeters, unless otherwise stated.

7. DISMOUNTING

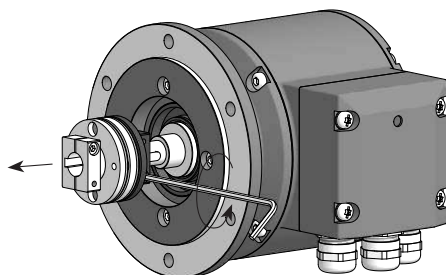
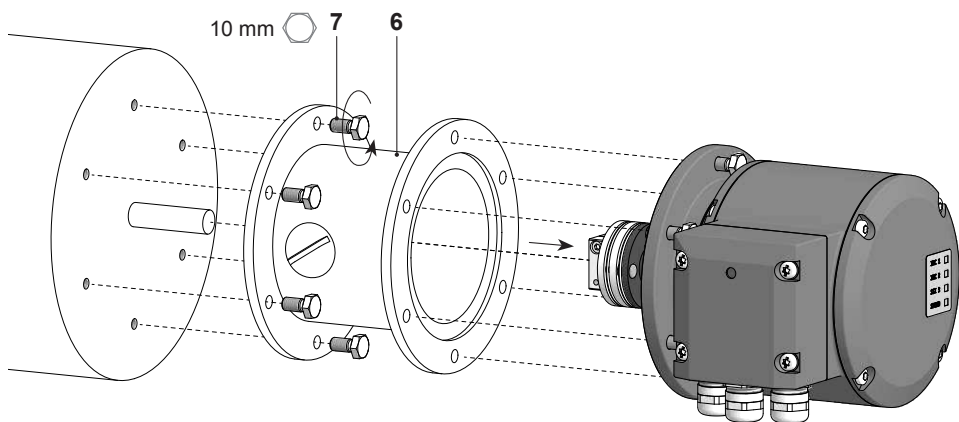
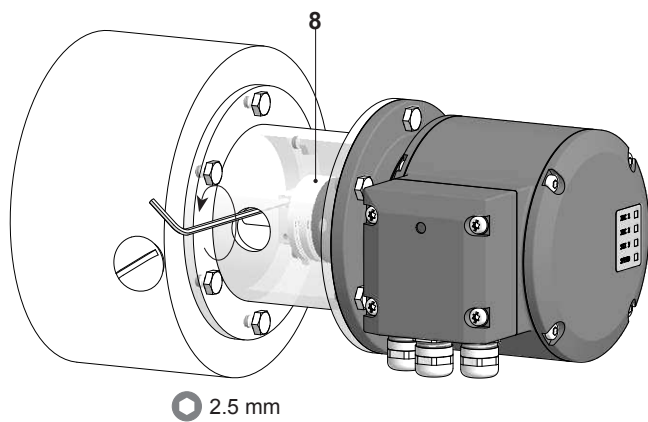

8. TECHNICAL DATA

8.1 Technical data - electrical ratings

Voltage supply	10...30 VDC
Short-circuit proof	Yes
Consumption w/o load	≤200 mA
Initializing time	≤500 ms after power on
Interface	CANopen®
Function	Multiturn
Transmission rate	10...1000 kBaud
Device adress	Rotary switches in bus connecting box (type-specific)
Steps per turn	8192 / 13 bit
Number of turns	65536 / 16 bit
Additional outputs	Square-wave HTL Square-wave TTL (RS422)
Sensing method	Magnetic
Interference immunity	EN 61000-6-2
Emitted interference	EN 61000-6-3
Programmable parameters	Steps per revolution Number of revolutions Preset, scaling, rotating direction
Diagnostic function	Position or parameter error
Status indicator	DUO-LED in bus connecting box 4 LEDs in device back side
Approvals	CE

8.2 Technical data - electrical ratings (speed switches)

Interface	RS485
Switching accuracy	±2 % (or Digit)
Switching outputs	1 output (Open-Collector* or Solid State Relay*)
Output switching capacity	30 VDC; ≤100 mA
Switching delay time	≤20 ms

* Depending on version

8.3 Technical data - mechanical design

Size (flange)	ø115 mm
Shaft type	ø11 mm solid shaft
Flange	EURO flange B10
Protection DIN EN 60529	IP 66/IP 67
Operating speed	≤6000 rpm
Range of switching speed	±2...6000 rpm, default 6000 rpm
Operating torque typ.	10 Ncm
Rotor moment of inertia	1 kgcm ²
Admitted shaft load	≤450 N axial ≤650 N radial
Materials	Housing: aluminium alloy Shaft: stainless steel
Operating temperature	-40...+85 °C
Relative humidity	95 % non-condensing
Resistance	IEC 60068-2-6 Vibration 30 g, 10-2000 Hz IEC 60068-2-27 Shock 400 g, 1 ms
Corrosion protection	IEC 60068-2-52 Salt mist Complies to ISO 12944-5:1998 Protective paint systems (C5-M)
Weight approx.	2.7 kg (depending on version)
Connection	Bus connecting box Terminal box speed switch/incremental



Baumer

Baumer Hübner GmbH

P.O. Box 12 69 43 · 10609 Berlin, Germany

Phone: +49 (0)30/69003-0 · Fax: +49 (0)30/69003-104

info@baumerhuebner.com · www.baumer.com/motion

Original language of this instruction is German. Technical modifications reserved.